

Figure 1. Sequential scanning (after Langacker 1987: 245)

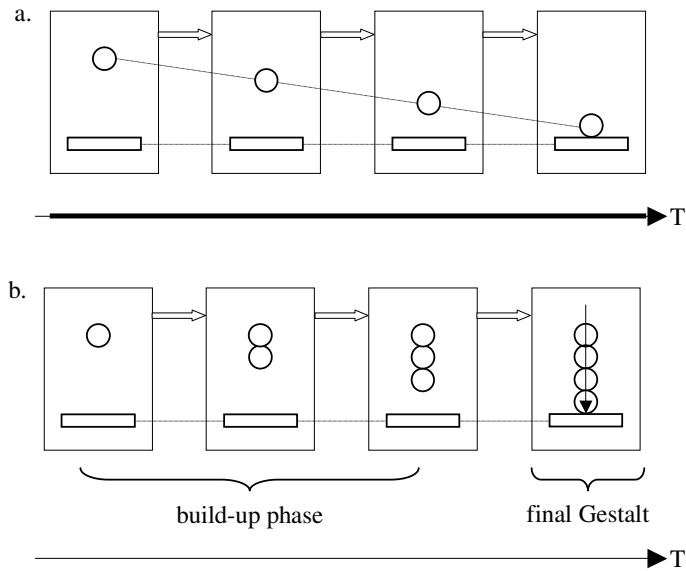

Figure 2. Sequential (a) vs. summary (b) scanning (after Langacker 1987: 144)

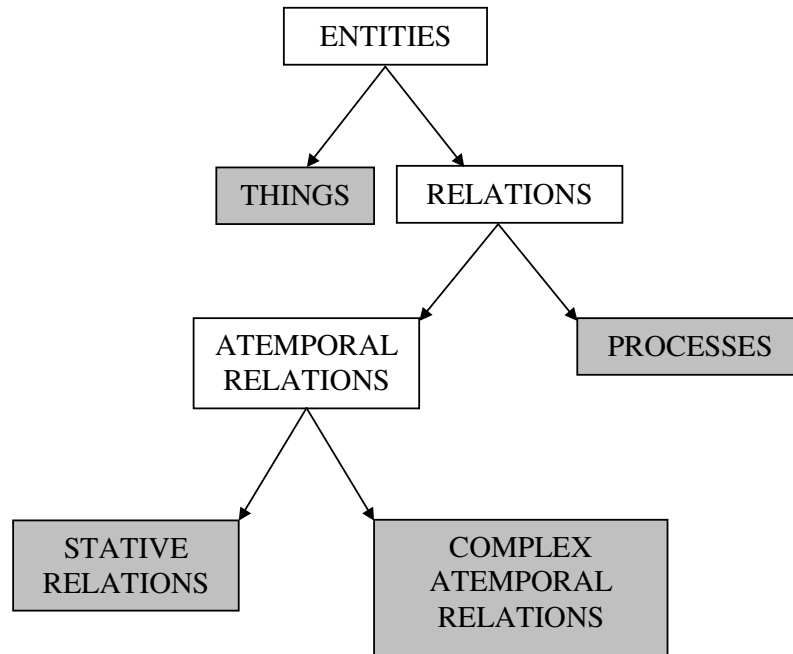

Figure 3. The Cognitive Grammar analysis of word classes

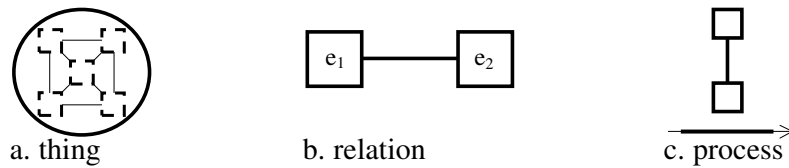

Figure 4. Schematic representations of things (a), relations (b) and processes (b)

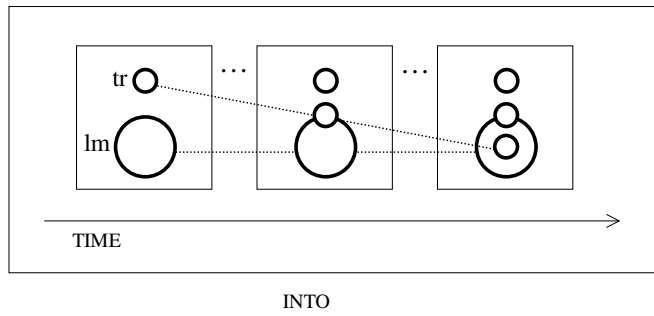
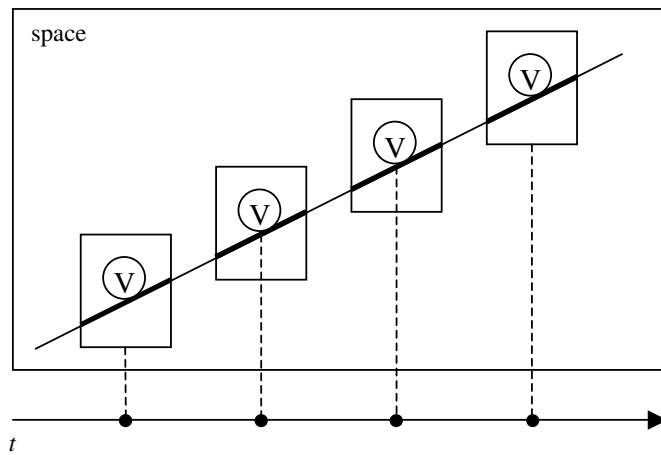

Figure 5. *Into* involves summary scanning

a. Perfective Virtual Motion



b. Imperfective Virtual Motion

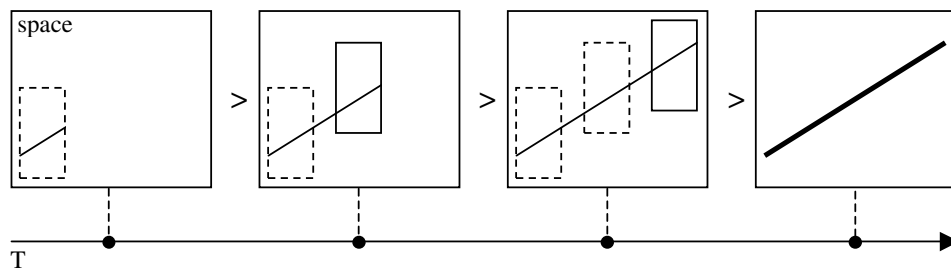

Figure 6. Fictive motion (after Langacker 2005:176)

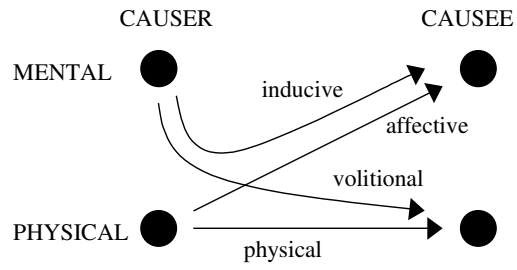

Figure 7. Talmy's typology of causation types (after Croft 1991: 167)

	punctuality	directness	relationality
cause	high	low	low
force	high	high	low
get	low	high	low
have	high	high	high
make	high	high	high
persuade	low	high	low

Table 1. Periphrastic causatives scored against the extended binding hierarchy for (implicative) causatives

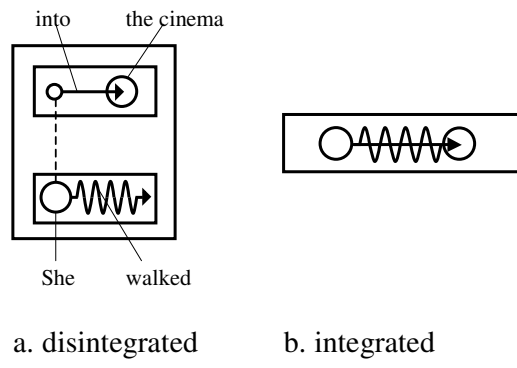

Figure 8. Schematic representation of *She walked into the cinema*

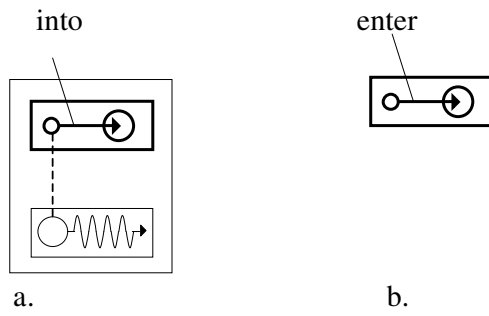

Figure 9. The semantic poles of *into* and *enter*